



INTERNATIONAL JOURNAL OF ENGINEERING SCIENCES & RESEARCH TECHNOLOGY

FPGA based Pollution Control System for Vehicles using Special Sensors

T. Deepa

Department of ECE, M.Tech VLSI Design, Bharath University, Chennai, India

tdeebu@gmail.com

Abstract

Now days, vehicle usage is very much higher. Most of the people are using gas fuel instead of petrol or diesel. This method is quite easy but on the other hand it is harmful also. So, these types of vehicles required proper monitoring. The project aims to modify an existing safety model employed in domestic field. The aim of this project is designing a FPGA based toxic gas detection, and if the gas has detected it automatically alert the owner and transmits the warning message to the authorized person and RTO department. This safety system can be used in any automation field, Houses etc. The monitoring of air quality inside vehicle is completely combined with original equipment. The monitoring system of harmful gas inside special vehicle has many advantages such as advance performance, high reliability, etc. The detection unit reaches the maximum threshold level, at the same detects any toxic gas it send an information using Zigbee. The advantage of this automated detection/alarm system is that it offers faster response time and accurate detection of an emergency in turn leading to faster diffusion of the situation, compared to manual methods. This is a very compelling reason that justifies designing such a safety system.

Keywords: CO Sensor, FPGA, RS232, VHDL, Zigbee

Introduction

The principal air-quality pollutant emissions from petrol, diesel and alternative fuel engines are carbon monoxide, oxides of nitrogen, un-burnt hydrocarbons and particulate matter. It is emissions of these pollutants that are regulated by the Euro emissions standards. Modern cars, if kept in good condition, produce only quite small quantities of the air quality pollutants, but the emissions from large numbers of cars add to a significant air quality problem. Carbon monoxide, oxides of nitrogen, and un-burnt hydrocarbons are gases, and are generally invisible. Particulate matter is usually invisible although under certain operating conditions diesel engines will produce visible particles, appearing as smoke. Petrol engines will also produce visible particles if they are burning engine oil or running "rich", for example, following a cold start. Fine particles can also be produced by tires and brake wear. Unlike emissions of CO₂, emissions of the air quality pollutants are not directly linked to fuel consumption. Pollutant emission levels depend more on vehicle technology and the state of maintenance of the vehicle. Other factors, such as driving style, driving conditions and ambient temperature also affect them. However, as a starting point, all new passenger cars must meet minimum EU emissions standards. The effects of

these exhaust gases are described in more detail below: **CO** - Carbon monoxide reduces the blood's oxygen carrying capacity which can reduce the availability of oxygen to key organs. Extreme levels of exposure, such as might occur due to blocked flues in domestic boilers, can be fatal. At lower concentrations CO may pose a health risk, particularly to those suffering from heart disease. **NOx** - Oxides of nitrogen react in the atmosphere to form nitrogen dioxide (NO₂) which can have adverse effects on health, particularly among people with respiratory illness. High levels of exposure have been linked with increased hospital admissions due to respiratory problems, while long term exposure may affect lung function and increase the response to allergens in sensitive people. NOx also contributes to smog formation, acid rain, can damage vegetation, contributes to ground level ozone formation and can react in the atmosphere to form fine particles ('secondary particles'). **Particulate matter (PM)** - Fine particles have an adverse effect on human health, particularly among those with existing respiratory disorders. Particulate matter is associated with increased hospital admissions due to respiratory and cardiovascular problems, bringing forward the deaths of those suffering from respiratory illnesses and a reduction in life expectancy. **HC** - Hydrocarbons,

contribute to ground level ozone formation leading to risk of damage to the human respiratory system.

CO Sensor

When the vehicle with the closed doors is entangled in a traffic jam or in a traffic signal, the CO from the exhaust of other nearby vehicles will be easily pulled in to the vehicle cabin which can create the major disaster to the persons inside the cabin. The proposed system has a sensor which detects the presence of CO inside the vehicle cabin. A CO sensor is a device that detects the presence of the CO gas in order to prevent the CO poisoning. MQ-7 CO sensor is mounted on the vehicle, will be automatically updating the status of the vehicle continuously. So, we can easily identify the excess gas emission status of the vehicle and stop the engine and alert the user. A simple electronic circuit is used which converts the change of conductivity to its corresponding output signal of gas concentration. MQ-7 gas sensor has high sensitivity to Carbon Monoxide. The sensor could be used to detect different gases contains CO and is a low cost and suitable for different applications



Fig 1. MQ-7 CO sensor

Structure and configuration of MQ-7 gas sensor

The sensor composed by micro AL2O3 ceramic tube, TinDioxide (SnO2) sensitive layer, measuring electrode and heater are fixed into a crust made by plastic and stainless steel net. The heater provides necessary work conditions for work of sensitive components. The enveloped MQ-7 have 6 pin, 4 of them are used to fetch signals, and other 2 are used for providing heating current.

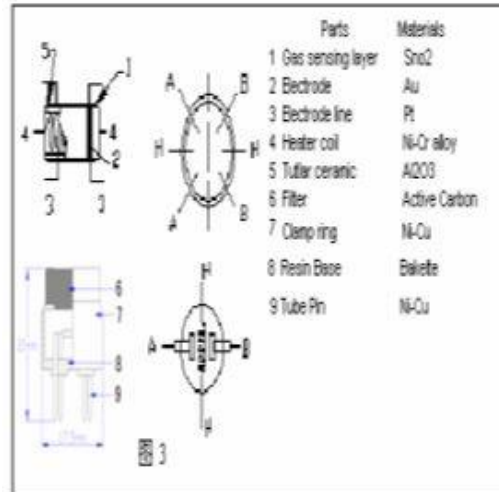

Fig 2. Structure and configuration of MQ-7 gas sensor

Sensitivity Characteristics

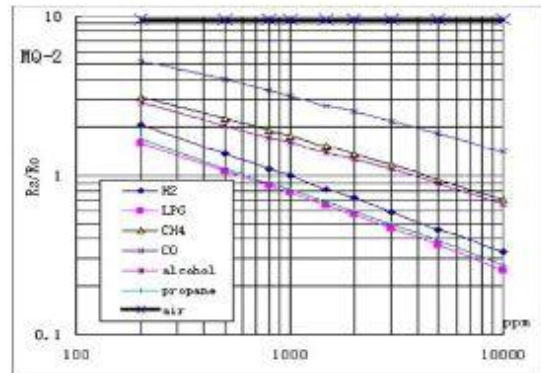

Fig 3. Sensitivity characteristics of MQ-7 Sensor

Electric parameter measurement circuit

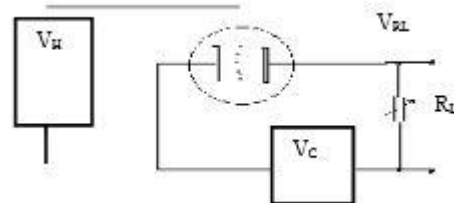

Fig 4. Electric parameter measurement circuit

The surface resistance of the sensor R_s is obtained through effected voltage signal output of the load resistance R_L which series-wound. The relationship between them is described:

$$R_s / R_L = (V_c - V_{RL}) / V_{RL} \text{ ----- (1)}$$

Fig shows alterable situation of R_L signal output measured by using circuit output signal when the sensor is shifted from clean air to carbon monoxide

(CO), output signal measurement is made within one or two complete heating period (2.5 minute from high voltage to low voltage). Sensitive layer of MQ-7 gas sensitive components is made of SnO₂ with stability, So, it has excellent long term stability. Its service life can reach 5 years under using condition.

temperature (heated by 1.5V) and the sensor's conductivity is higher along with the gas concentration rising. When high temperature (heated by 5.0V), it cleans the other gases adsorbed under low temperature. A simple electronic circuit is used which converts the change of conductivity to its corresponding output signal of gas concentration. MQ-7 gas sensor has high sensitivity to Carbon Monoxide. The sensor could be used to detect different gases contains CO and is a low cost and suitable for different applications. If the emission exceeds the threshold level, the FPGA unit makes the buzzer to alarm to alert the user and displays that information using LCD. If the gas has detected it automatically alert the owner and transmits the warning message to the authorized person and RTO department using zigbee. Fig 6 shows the receiver section of the proposed system. Here another zigbee is used to receive the signal that is transmitted. In the RTO department, the information obtained is maintained in a database. Here the transferring of information to the RTO department is achieved by wireless technology.

Block Diagram of the Proposed Method

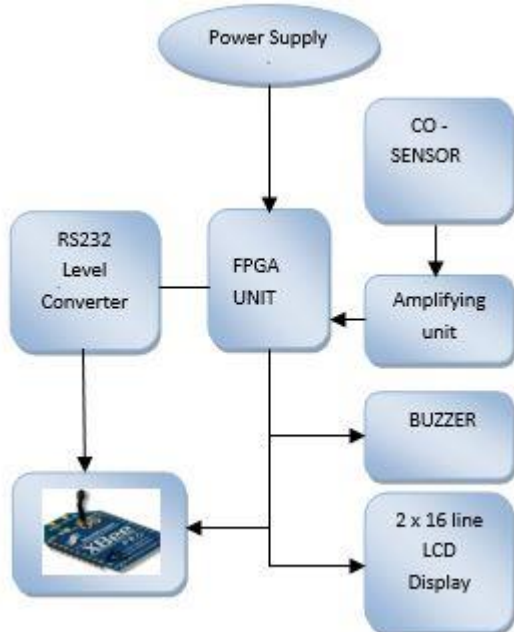

Fig 5. Transmitter section



Fig 6. Receiver section (RTO)

Fig 5 shows the Transmitter section of the proposed system. In this section MQ-7 Carbon Monoxide sensor is used. Sensitive material of MQ-7 gas sensor is SnO₂, with lower conductivity in clean air. It make detection by the method of cycle high and low temperature, and detects CO when low

ZIGBEE Module

The XBee/XBee-PRO RF Modules are designed to operate within the ZigBee protocol and support the unique needs of low-cost, low-power wireless sensor networks. The modules require minimal power and provide reliable delivery of data between remote devices. The modules operate within the ISM 2.4 GHz frequency band and are compatible. The XBee modules were designed to mount into a receptacle (socket) and therefore do not require any soldering when mounting it to a board. The XBee-PRO Development Kits contain RS-232 and USB interface boards which use two 20-pin receptacles to receive modules.

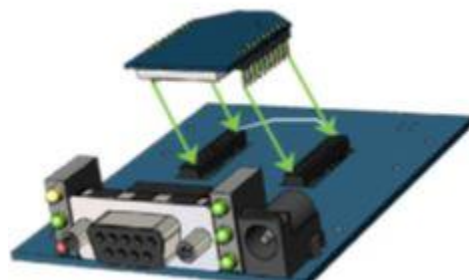

Fig 7. Zigbee Module Mounting to an RS232 Interface Board

Conclusion

In this paper the proposed system is implementing by integrating FPGA, Gas sensor and zigbee for efficient and economic pollution control from

vehicles. The system also provides improved database for the vehicle that causes excess emission. The application includes Highway transport, vehicle speed control, Vehicle fitness control, Pollution control. The simulation is done using Xilinx. The system also provides improved database for the vehicle that causes excess emission. It is a more safety system that uses systematic approach for monitoring and control and uses easy way of sensing gas and intimating the authorized person and RTO department through wireless technologies.

References

- [1] H. Kawasaki, T. Ueda, Y. Suda , and T. Ohshima, *Sensors and Actuators B*, vol. 100, p. 266,2004.
- [2] U. Guth and J. Zosel , *Ionics*, vol. 10, p. 366, 2004.
- [3] M. W. Son, J. B. Choi , H. J. Kim, K. S. Yoo , and S. D. Kim, *J. Kor. Phys. Soc.*, vol. 54, p.1072, 2009.
- [4] H. B. Shim, J. H. Kang, J. W. Choi, and K. S. Yoo , *J. Electroceram.*, vol. 17, p. 971, 2006.
- [5] M. W. Son, J. B. Choi , H. I. Hwang, and K. S. Yoo , *J. Kor. Sensors Soc.*, vol. 18, p. 263, 2009.
- [6] D. L. West, F. C. Montgomery, and T. R. Armstrong, *Sensors and Actuators B*, vol. 106, p.758, 2005.
- [7] H. S. Kang, S. W. Kim, and Y. J. Cho, *J. Kor. Furni. Soc.*, vol. 18, p. 91, 2007.
- [8] H. J. An, C. H. Cheong, H. J. Kim, and Y. G. Lee, *J. Archi. Ins. Kor.*, vol. 25, p. 51, 2005.
- [9] C.-Y. lin, Y.-Y. Fang, C.-W. Lin, J. J. Tunney, and K.-C. Ho, *Sensors and Actuators B*, vol.146, p. 28, 2010.
- [10]A. Serra, M. Re, M. Palmisano, M. V. Antisari, E. Filippo, A. Buccolieri, and D. Manno,*Sensors and Actuators B*, vol. 145, p. 794, 2010.
- [11]P.-G. Su and T.-T. Pan, *Mater. Chem. and Phys.*, vol. 125, p. 351, 2011.